

# FRONT VIEW

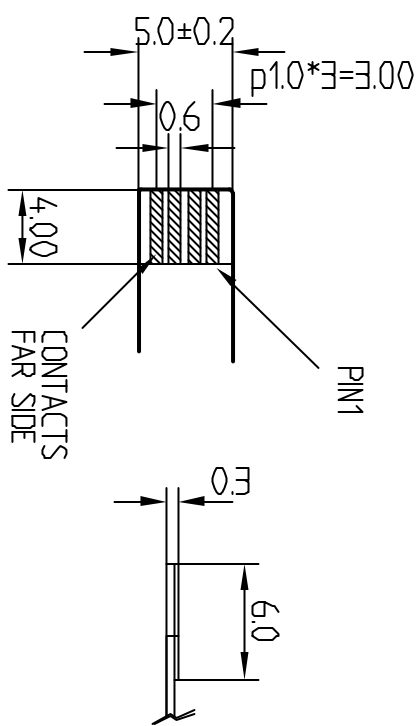
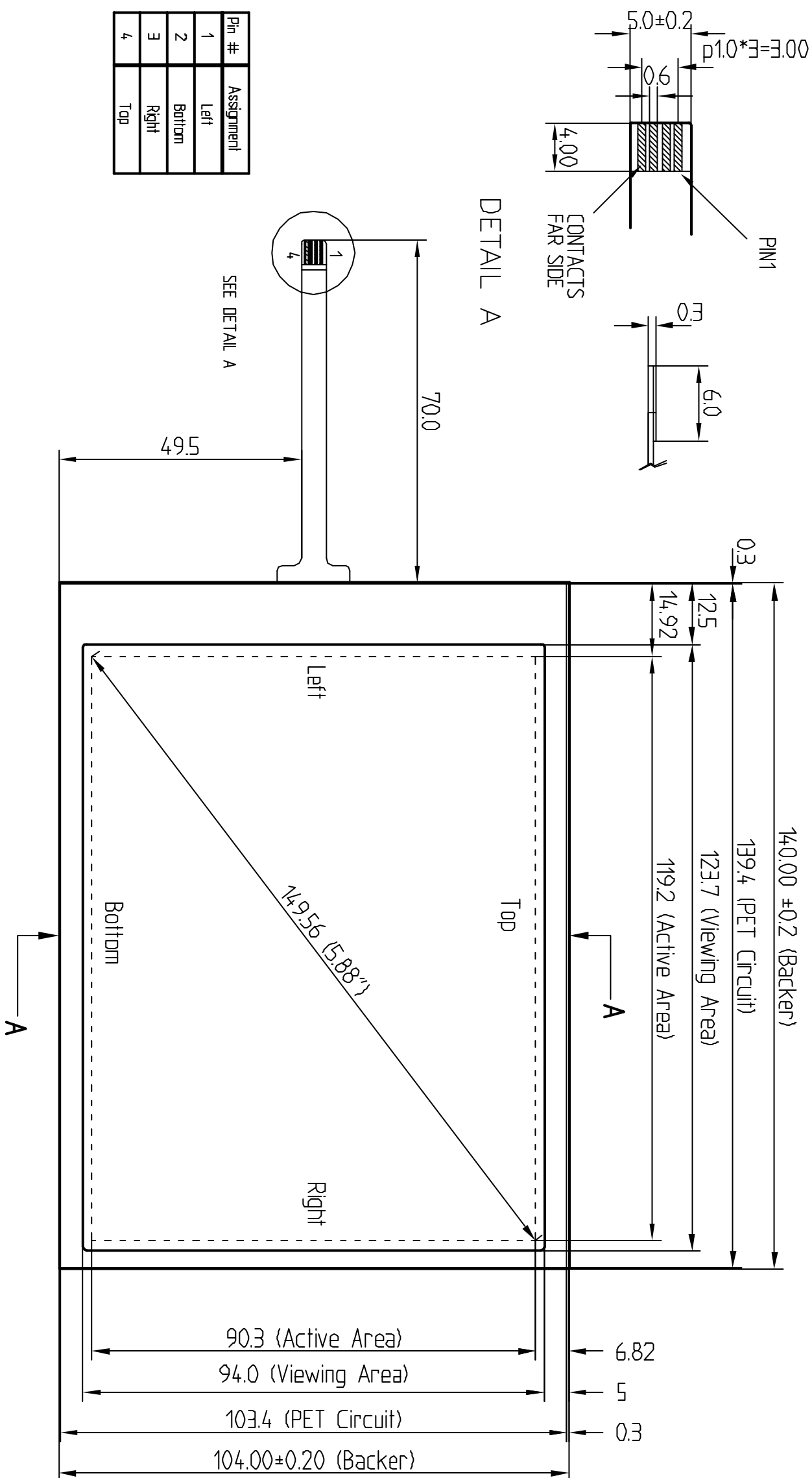

Pin #	Assignment
1	Left
2	Bottom
3	Right
4	Top

SEE DETAIL A

## NOTES:

1. ITO GLASS THICKNESS : 1.1mm
2. ITO PET TOP CIRCUIT THICKNESS : 0.2mm
3. SPACER ADHESIVE : 0.1mm
4. OVERALL THICKNESS : 1.40mm ±0.07
5. CONNECTOR AND PINOUT AS INDICATED
6. DOTS : 0.1mm Dia. on 4.0mm CENTERS
7. FRONT SURFACE ANTIGLARE HARDCOAT
8. OPTICAL SPECIFICATION : A001
9. LAYER TO LAYER ASSEMBLY TOLERANCE: ±0.3mm
10. FPC TAIL

SECTION A-A

- Hardcoat
- 0.2mm ITO PET
- 0.1mm Spacer Adhesive
- 1.1mm ITO Glass

REV.	MODIFIKAT.	DATE	NAME	ARTICLEL
		2002		
		PROVIDER	23.10.	Hilt
		APPROVED	23.10.	Maurer
TOLERANCES UNLESS SPECIFIED				SCALE
X = ±0.5				1 : 1
XX = ±0.25				UNIT
XXX = ±0.10				mm
D-79346 Endlingen				AMT-DWG-NR. 9504-H01 / REV. A
SCHURTER				SCHURTER-ORDER-NR.
1070.0420				1070.0420
SHEET 1 OF 1				REV

TOUCH 5,88" 4 WIRE